

IMPACT OF SOIL PARAMETERS ON WEATHER FORECASTS USING SOFT COMPUTING

Elena García^{1*}, Luis Martínez², Isabel Romero³

¹Departamento de Ingeniería Informática, Universidad de Granada, Granada, Spain

²Departamento de Ciencias de la Computación, Universidad de Granada, Granada, Spain

³Facultad de Matemáticas, Universidad de Granada, Granada, Spain

ABSTRACT

Weather forecasting is the application of science and technology to predict the state of the atmosphere for a given location and they are made by collecting quantitative data of soil parameters. Soft computing is an innovative approach to construct computationally intelligent systems that are supposed to possess humanlike expertise within a specific domain, adapt themselves and learn to do better in changing environments, and explain how they make decisions. Soft computing techniques are Fuzzy logic, Neural Network, Ant Colony Optimization, Genetic Algorithm etc. In this paper description about the soil and new technologies.

Keywords: *Weather Forecasting, Soft computing, Fuzzy Logic, Neural Network, Ant Colony Optimization.*

I. INTRODUCTION

Soils are basic to Civilization Supplying various economic and cultural services as well as being the substrate for plant and with water it constitute society's most important, source as a life support system. They provide food, fibre, supportbuilding and road help to convert sunlight to usable forms of energy and other resource. Soil the outermost layers of the earth is a product of geological processes and human intervention. Soils are integral and vital part of our environment and may be defined as discrete bodies produced by interaction of climate, vegetation and surficial geological materials on earth Surface. It is composed of minerals altered physically and chemically from original bed rock, organic chemicals and biomass and pore space fill with air water and dissolved material. The quality and security of soil have always affected human civilization. Man has made soil fertile on large scale, providing more source food resource for the ever-growing population. Yet there is a good threat of soil in many instance, on marginal soils or in less resilient soil region. A good environment ethic requires equally good soil care of open spaces and forests, woods and desert for better quality of life future generations of town country populations.

The word soil means different things to different people. It can be (I)organized body of nature (II) a Substrate for plant growth (III)physical ground on which housing industries and roads and constructed. Soils are dynamic natural bodies comprising the upper most layer of earth exhibiting distinct organization of their mineral and organic components including water and air which formed in response to atmospheric and biosphere force acting on various parent materials under diverse topographic conditions over a period of time.

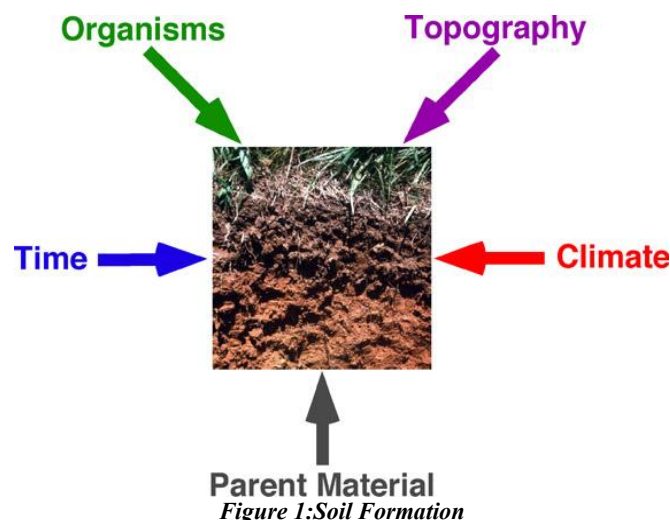

Figure 1: Soil Formation

Weather prediction is said to be the ultimate goal of atmospheric research. It is also described as the most advanced area in meteorology. The nature of modern weather forecasting is not only highly complex but also highly quantitative. The various procedures adopted in weather analysis and weather prediction are certainly beyond the scope of a textbook of Climatology. An attempt, therefore, is made to highlight the different methods used in modern weather forecasting. The various methods used in forecasting the weather are as follows:

- (1) Synoptic weather forecasting,
- (2) Numerical methods, and
- (3) Statistical methods.

Each of these methods aims at not only projecting the location and possible intensification of existing pressure systems, but also determining the creation of new storm centers.

(1) Synoptic weather forecasting:

It is the traditional approach in weather prediction. This primary method continued to be in use until the late 1950s. Here it would be in the fitness of things that the meaning of the word “synoptic” should be made clear to the reader. Synoptic” means that the observation of different weather elements refers to a specific time of observation.

Thus, a weather map that depicts atmospheric conditions at a given time is a synoptic chart to a meteorologist. In order to have an average view of the changing pattern of weather, a modern meteorological center prepares a series of synoptic charts every day.

Such synoptic charts form the very basis of weather forecasts. As stated earlier, the task of preparing synoptic charts on a regular basis involves huge collection and analysis of observational data obtained from thousands of weather stations.

From the careful study of weather charts over many years, certain empirical rules were formulated. These rules helped the forecaster in estimating the rate and direction of the movement of weather systems.

(2) Numerical methods:

More recently it has been realized that other methods can more accurately predict the future weather than was possible by the traditional synoptic approach. The numerical method involves a lot of mathematics.

Modern weather forecasting is now using the techniques of Numerical Weather Prediction (NWP). This method is based on the fact that gases of the atmosphere follow a number of physical principles. If the current conditions of the atmosphere are known, these physical laws may be used to forecast the future weather.

Since the late 1940s there has been a steady growth as regards the use of mathematical models in weather forecasting. These procedures have been made possible because of advancement in the formulation of mathematical models.

A series of mathematical equations is used to develop theoretical models of the general circulation of the atmosphere. These equations are also used to specify changes in the atmosphere as the time passes on.

For these equations certain weather elements like air movements, temperatures, humidity, evaporation at the ground, clouds, rain, snow and interactions of air with ground and oceans are taken into account.

The National Weather Service for its daily weather prediction makes use of a numerical model in which the atmosphere is divided into 6 distinct layers. In certain cases, the atmosphere is divided into as many as 11 layers.

The use of mathematical models makes it necessary that the initial state of the atmosphere is completely known. This is made possible by making observations of the atmosphere by means of radiosonde stations all over the world.

Limitations of Numerical Method of weather forecasting have to be taken into account. “The physical assumptions adopted and the degree of sophistication of each physical process incorporated differs from model to model.”

Numerical forecasting is beset with a large number of problems.

(3) Statistical methods:

Statistical methods are used along with the numerical weather prediction. This method often supplements the numerical method. Statistical methods use the past records of weather data on the assumption that future will be a repetition of the past weather.

The main purpose of studying the past weather data is to find out those aspects of the weather that are good indicators of the future events. After establishing these relationships, correct data can be safely used to predict the future conditions.

Only overall weather can be predicted in this way. It is particularly of use in projecting only one aspect of the weather at a time. For example, it is of great value in predicting the maximum temperature for a day at a particular place.

Statistical methods are of great value in long-range weather forecasts. The National Weather Service prepares monthly and weekly weather outlooks. In fact these are not weather forecasts in the strict sense of the term.

In this paper we are considering an easy method for the weather prediction. Using the soil parameters, weather can be predicted. For the weather prediction new technique.

Soft computing

Soft computing is the use of approximate calculations to provide imprecise but usable solutions to complex computational problems. The approach enables solutions for problems that may be either unsolvable or just too time consuming to solve with current hardware. Soft computing is sometimes referred to as computational intelligence.

Soft computing uses component fields of study in:

- (1) Fuzzy Logic
- (2) Ant colony optimization
- (3) Artificial Neural Network

Fuzzy logic is an extension of classical logic. The main difference between fuzzy logic and classical logic is that fuzzy set is used for membership of a variable.

Fuzzy logic has many advantages over classical logic in areas like artificial intelligence where a simple true/false statement is insufficient.

Humans are very good at recognizing by eye what they are looking at but computers are better at counting and measuring. Fuzzy Logic is very helpful in guiding computers to find the right thing to measure and calculate. Real-world attributes are known by human perceptions through quality and quantity appreciations linguistically or by measurements. Different questions may be asked about individual or joint behaviours of these attributes. Humans continue to acquire knowledge by perception, which is a never-ending process.

Fuzziness is a paramount characteristic of human perception that challenges humanity and propels the search for truth and understanding the secrets of reality. The fuzziness in human perception reveals ways of transcending it, and thus expanding the field of human inquiry. Fuzzy impressions and concepts are generated by the human mind, and it divides the see-able hydrological, environmental, or engineering reality into fragments and categories, which are fundamental ingredients in the classification, analysis, and deduction of conclusions after labelling each fragment with a word such as "name," "noun," or "adjective".

Fuzzy logic has two different meanings. In a narrow sense, fuzzy logic is a logical system, which is an extension of multivalued logic and in a wider sense fuzzy logic is almost synonymous with the theory of fuzzy sets, a theory which relates to classes of objects in which membership is a matter of degree. Even in its more narrow definition, fuzzy logic differs both in concept and substance from traditional multivalued logical systems.

Fuzzy Logic

Here is a list of general observations about fuzzy logic:

- Fuzzy logic is conceptually easy to understand.
- Fuzzy logic is a more intuitive
- Fuzzy logic is flexible.
- Fuzzy logic is tolerant of imprecise data

Fuzzy Logic is present trend for decision making, classification and prediction where problem can be formulated by mapping input variable with output variable or where simple solution does not exist. There are three basic steps for fuzzy inference system such as Fuzzification, rule evaluation and Defuzzification.

Fuzzification means converting numeric value into linguistic value. Human intuition method is well accepted method for the membership function value assignment throughout the world. Fuzzy inference engine produces the result after rule evaluation also in terms of linguistic value.

II. LITERATURE SURVEY

Soil is an important habitat for both producers (green plants) and decomposers (bacteria and fungi). While air and water are both self-purifying systems with regard to most inorganic contaminants, soil is a sink - receiving fall-out from the atmosphere which it absorbs or filters, and could retain materials from infiltrating natural waters. Soil also serves as nature's recycling system, it provides habitat for a myriad of living organisms and in human built ecosystems, and it serves as engineering medium (Karle et al., 1997).

McBride et al., 1997, studied the mobility and solubility of toxic metals and nutrient in soil fifteen years after sludge application. Base on the elemental deficits calculated using soil chromium concentration as an indicator of the original sludge concentration in the soil, it is estimated that most of the sludge -applied Na, S, Ca and Sr, about 40% of the Zn and Cu and less than 30% of the Cd and P have been lost from the top soil surface by physical -chemical or biological processes and there is potential for groundwater and surface water contamination.

The livelihood of over 60 per cent of the world's population depends upon the monsoons, of which the Asian summer monsoon is the largest. Accurate predictions of the monsoons, at least a season in advance, are therefore crucial for the monsoon regions. Furthermore, the Asian summer monsoon is a key component of the earth's climate system, having important tele-connections with global weather and climate (Walter Maner, 1997).

Following the Great Indian Drought of 1877, H.F. Blanford, who had established the India Meteorological Department in 1875, issued the first seasonal forecast of Indian monsoon rainfall in 1884. Later, in the early part of the 20th century, Sir Gilbert Walker initiated extensive studies of global teleconnections which led him to the discovery of Southern Oscillation. Walker introduced, for the first time, the concept of correlation for long-range forecasting of the Asian summer monsoon and his findings are relevant even today.

The implementation of ANN, an important Soft Computing methodology in weather forecasting has started by Hu (1964). Özelkan and Duckstein (1996) compared the performance of regression analysis and fuzzy logic in studying the relationship between monthly atmospheric circulation patterns and precipitation. Cook and Wolfe (1991) developed a neural network to predict the average air temperatures. Fuzzy logic can also be of great use in the atmospheric data analysis and prediction. Being capable of dealing with linguistic variables, this methodology can be utilized in analyzing atmospheric variables. Liu and Chandrasekar (2000) developed a fuzzy logic and neurofuzzy system for classification of a hydrometeor type based on polarimetric radar measurements where fuzzy logic was used to infer a hydrometeor type and the neural network-learning algorithm was used for automatic adjustment of the parameters of the fuzzy sets in the fuzzy logic system according to the prior knowledge (Mehmet Tektas, 2010).

Neural networks and fuzzy inference systems have been widely used in several intelligent multimedia applications. Artificial Neural Network (ANN) learns from scratch by adjusting the interconnections between layers. Fuzzy Inference System (FIS) is a popular computing framework based on the concept of fuzzy set theory, fuzzy if-then rules, and fuzzy reasoning. Integrating ANN and FIS have attracted the growing interest of researchers due to the growing need of adaptive intelligent systems to meet the real world requirements (Abraham, 2001).

Fuzzy logic systems, which can work with imprecise information, are good at explaining their decisions but they cannot automatically acquire the rules they use to make those decisions. A fuzzy system demands linguistic rules instead of learning examples as prior knowledge. Furthermore the input and output variables have to be described linguistically. If the knowledge is incomplete, wrong or contradictory, then the fuzzy system must be tuned (Fuller, 1995).

Hybridization of systems combining Fuzzy logic, Neural Networks are proving their effectiveness in a wide area of real world problems. Every intelligent system has particular ability to learn that make them suited for particular problems and not for others (Fuller, 1995).

Moreover, it is clear that the performance of ANFIS can predict weather condition accurately. Gholam Abbas (2009), Maqsood et al. (2004), Paras et al. (2008), Singh et al. (2006), Abraham et al. (2004), uses temperature, relative humidity and vapour pressure.

III. SYSTEM METHODOLOGY

The project aims to implement weather forecast system using soil parameters using Fuzzy logic. Using pH sensor, Temperature sensor, moisture sensor we sense the values from the soil. Then the conditions are analysed using fuzzy controller. This project shows the communication between the Micro controller and Raspberry pi.

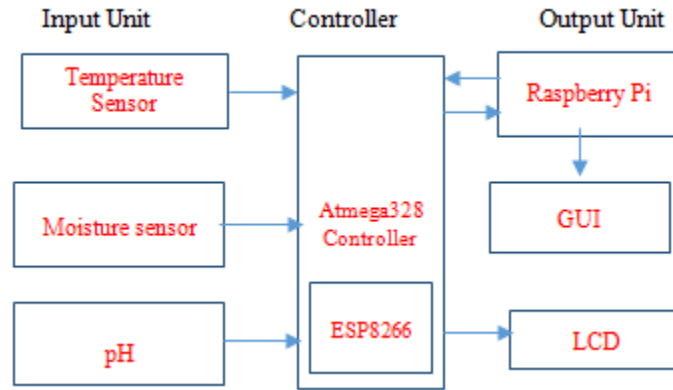

Figure 2: Block Diagram

First using temperature sensor, pH sensor, moisture sensor we collect the values. The data was uploaded to the cloud using "Think speak server". This will allow the system to be monitored from anywhere using an internet connection. The data collected through Thing speak server was given as input to the fuzzy logic controller. The software implementation was done in Python with help of the Arduino controller and Raspberry pi.

Date and Time	SI NO	Temperature Values	Moisture Values	pH
2019-03-16 09:45:40 UTC	1	49	-1	-1
2019-03-16 09:56:02 UTC	2	0	-1	-1
2019-03-16 09:58:38 UTC	3	1	1	1
2019-03-17 07:10:22 UTC	4	29.63	1	-6
2019-03-17 07:29:40 UTC	5	28.75	1	-6
2019-03-17 09:37:45 UTC	6	32.51	1	-5
2019-03-17 09:38:09 UTC	7	32.07	1	-4
2019-03-17 09:38:34 UTC	8	34.56	1	-4
2019-03-17 09:38:59 UTC	9	32.47	1	-4
2019-03-17 09:39:22 UTC	10	31.24	1	-4
2019-03-17 10:34:47 UTC	11	39.79	0	5
2019-03-17 10:35:39 UTC	12	33.34	1	-7
2019-03-17 11:08:46 UTC	13	30.81	1	-6
2019-03-17 11:10:16 UTC	14	31.73	37	1
2019-03-17 11:10:40 UTC	15	32.76	35	1
2019-03-17 11:11:05 UTC	16	31.49	34	1
2019-03-17 11:11:30 UTC	17	32.17	33	0
2019-03-17 11:11:55 UTC	18	32.71	32	0
2019-03-17 11:12:19 UTC	19	31.83	31	0

Figure 3: Tabulation

The data will store like spreadsheet in thing speak. We can download the values as data sheet at any time. Program code is implemented in Python using skfuzzy library for fuzzy logic. Then the output is displayed in the graphical user interface. There we can see the sensor values, the weather that is to be predicted and a graph related to it.

A. Hardware & Software Used

1) **Arduino:** Atmega328 is an Atmel microcontroller, which is used in Arduino UNO board. Atmega328 has 28 pins in total. Total ATmega328 has 14 digital pins. Here Atmega 328 is the main part of the system. It will sense the value from the sensors and store in the cloud and displayed in LCD and passes to Raspberry Pi.

2) **Raspberry pi:** The Raspberry Pi 3 Model B is a tiny credit card size computer. Just add a keyboard, mouse, display, power supply, micro SD card with installed Linux Distribution and you'll have a fully-fledged computer that can run applications from word processors and spreadsheets to games.

3) **Temperature sensor:** Here the temperature sensor is LM35. The LM35 series are precision integrated-circuit temperature devices with an output voltage linearly-proportional to the Centigrade temperature. It operates from +4V to +30V.

4) Moisture Sensor: The Moisture sensor is used to measure the water content(moisture) of soil. When the soil is having water shortage, the module output is at high level, else the output is at low level. This sensor reminds the user to water their plants and also monitors the moisture content of soil.

5) pH sensor: Soil can be acid, neutral or alkaline, according to its pH value. Most plants prefer a pH range from 5.5 to 7.5; but some species prefer more acid or alkaline soils. Nevertheless, every plant requires a particular range of pH, for optimum growth.

6) LCD Display: LCD display is used to display the measurements of sensors. It will display the current temperature moisture and pH of the soil.

B. Fuzzy Logic

Fuzzy logic is the most advanced technology to provide solutions to the multiple parameters. In fuzzy logic, a set of rules created based on the data values collected from the sensors. Then the membership functions of collected data is created in a particular range. Fuzzy logic is an effective in feedback control system and easier to implement. The computational structure of fuzzy logic is composed of Fuzzification, Inference engine and Defuzzification modules.

IV. EXPERIMENTAL DESIGN OF SYSTEM

The system consist three sensors, that is temperature sensor, pH sensor, moisture sensor which is dipped inside soil. The sensor values measured through sensor is connected. To the arduino controller. The sensor values are store in the cloud using thing speak. The program code is written in the raspberry pi. The sensor values took as the input to the program code.

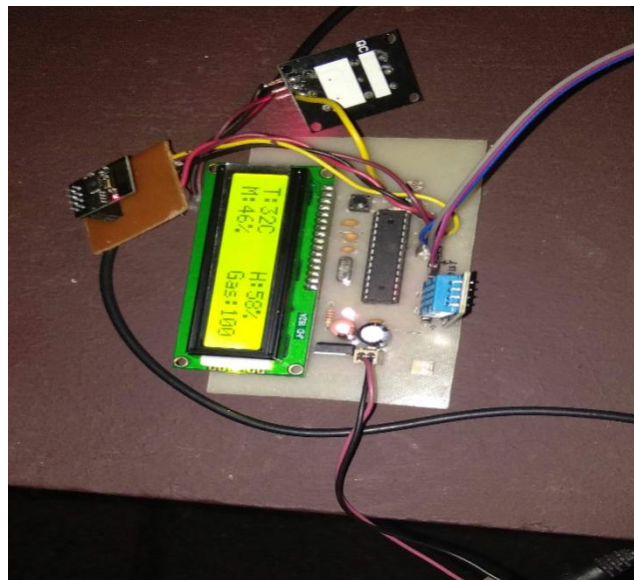
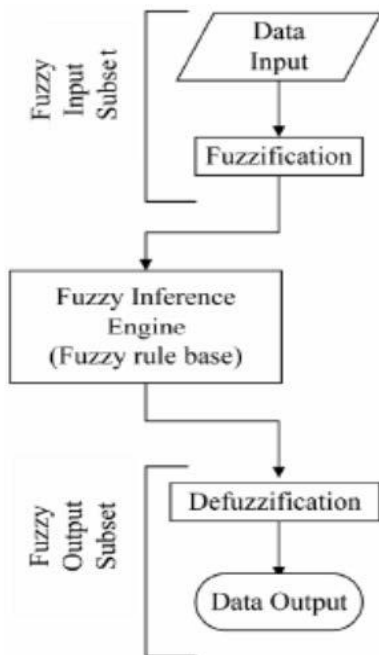

Figure 4: System Design

A LCD connected to the arduino controller which will displays the sensor outputs. Here fuzzy control is given in the code. After taking the values, it will do necessary calculation and produce the output.



Basic structure of a fuzzy inference model.

The fuzzy logic calculation use three parameters as variables. That is value of soil moisture sensor, temperature sensor, pH sensor. The fuzzy logic algorithm determined linguistic value of each variable. The fuzzification module will map the numeric value to fuzzy sets. Input value will be converted into input fuzzy as linguistic value.

V. RESULTS AND ANALYSIS

In this system, consists of weather prediction using soil parameters.

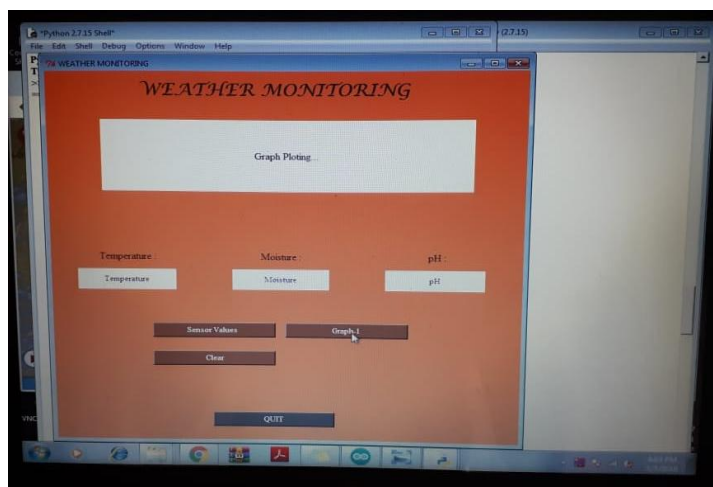
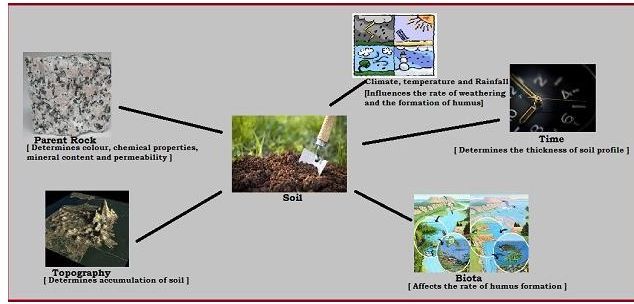

Figure 5:GUI

In this weather monitoring is done. By clicking the sensor values the sensors will sense the value from soil and the data is passes to the controller. It can see in the relevant boxes given to it. After the necessary calculations it will predict the weather. After collecting relevant values, by clicking the graph1 we can see the graph using the data.

Analysis:

[1] Soil Formation



[2] Soil parameters

TABLE -2, Mean Value of Various Soil Quality Parameters

Site	Moisture%	pH	E.C.ds/m	Heavy Metals in $\mu\text{g/g}$			
				Lead	Copper	Cadmium	Zinc
1.	15.68	7.79	3.81	19.86	15.25	0.74	32.82
2.	7.57	8.48	2.03	20.99	14.00	0.84	27.25
3.	9.68	8.02	2.90	21.14	14.21	0.61	31.57
4.	11.50	9.57	3.05	29.21	16.66	0.85	41.19
5.	8.23	7.82	2.69	20.63	14.96	0.56	27.16
6.	10.43	8.17	2.97	31.37	15.71	0.71	41.92
7.	16.58	6.02	4.05	15.07	14.92	0.76	30.56
8.	11.60	8.29	2.30	20.97	12.19	0.37	39.51
9.	5.45	7.01	2.89	27.70	16.69	0.70	40.68
10.	8.89	8.83	2.34	24.06	10.54	0.56	49.53
11.	8.24	7.89	3.22	20.82	13.48	0.65	28.20
12.	10.29	8.03	1.80	37.62	15.83	0.50	41.18

Graph that show the variation of parameters in different seasons.

[1] Summer: Temperature variation

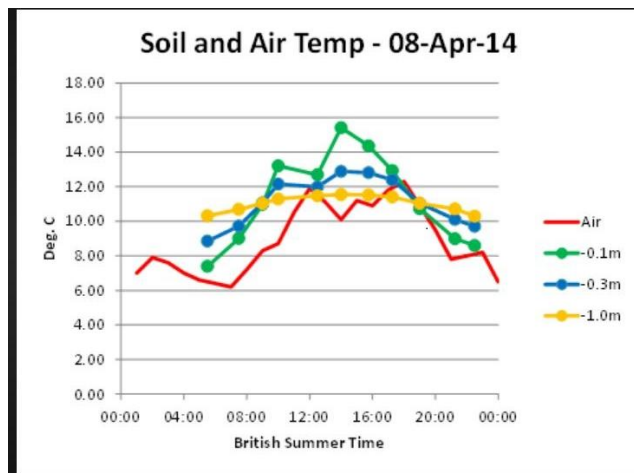

Moisture Variation:

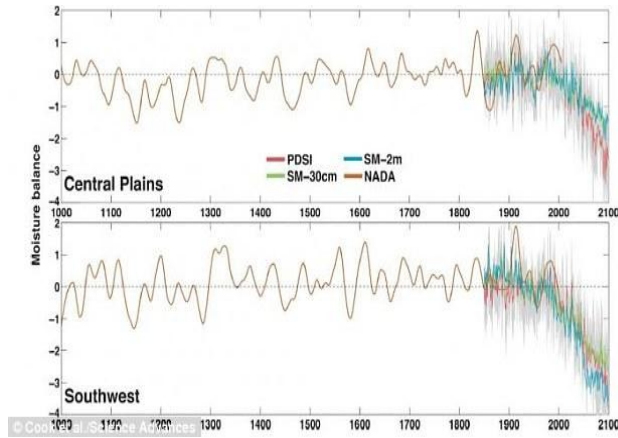

[2]Rainy: Temperature Variations

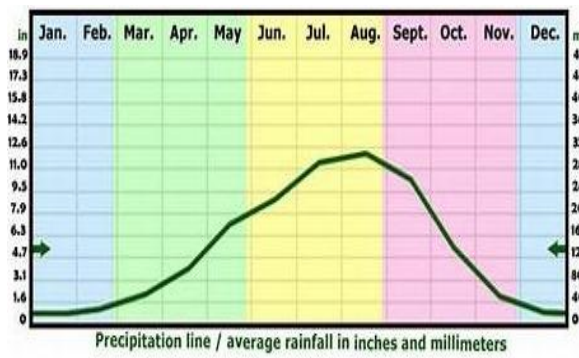

Moisture Variations:

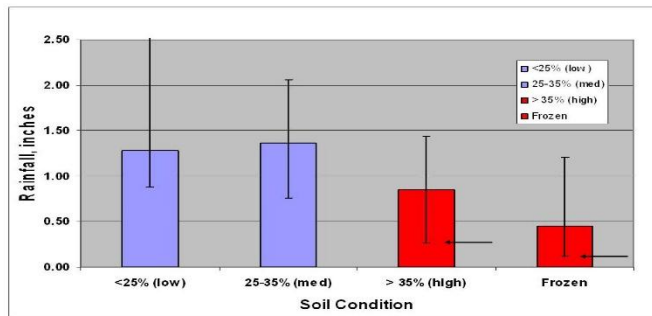

[3]Drought: Temperature Variations

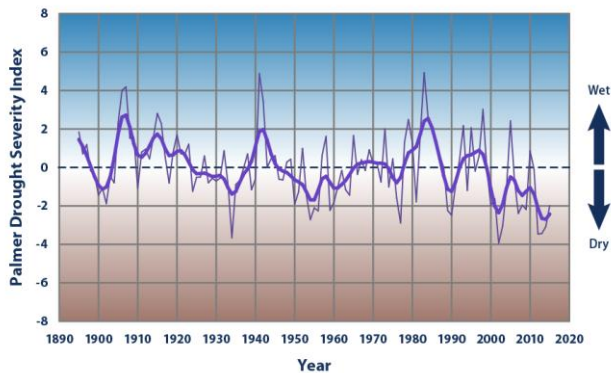

Moisture Variations:

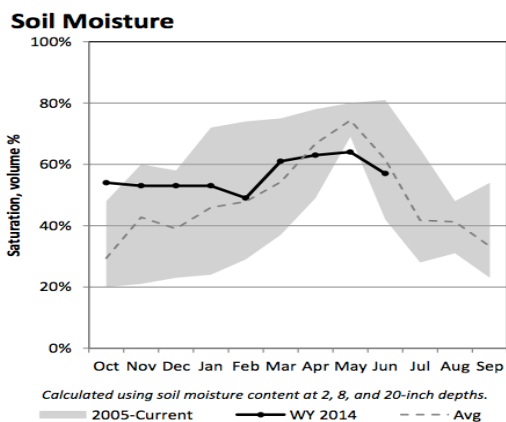

VI. CONCLUSION

Using this system we can predict the weather forecast. Here the three sensor values are taken as input to the system. After doing necessary calculation it will produce the output. Here we use the fuzzy logic in computing part. It is an analytic tool for the system. It is easiest for the farmers to predict weather. It is a new technology that can be implemented.

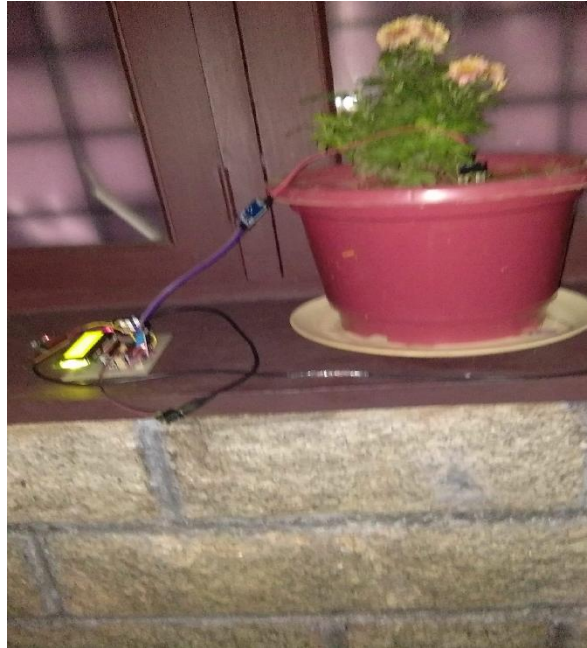

REFERENCE

1. Arnold, R.W., *Soils & Man. The conflict continues*, Int - Symp. Soils, Human And Environ .Z. CaO(ed), Interactions China Sci. and Technol . Press, Beijing (1998).
2. Yaalun , DH. And Arnold .R.W., *Attitude toward soils and their societal relevance:Then And Now . Soil Science 165: 15-12(2000).*
3. Mitchell R. L., *Trace Elements in Soils . Min Agric .(G Brit.) Tech .Bull 21: 8-20 (1971).*
4. Kandeler .E. Kampichler .C. Horak O, *Influence of heavy metals on the functional diversity of soil microbial communities .Biol .Fertil . Soils 23: 299-306 (1996).*
5. Mayer B..Roubuch M., *Different source of heavy metals and their long -term effect on soil properties. Biols. Fertil Soils 34: 241-247 (2001).*
6. *A PRELIMINARY ASSESSMENT OF THE IMPACT OF SMAP SOIL MOISTURE ON NUMERICAL WEATHER FORECASTS FROM GFS AND NUWRF MODELS* Xiwu Zhan¹, Weizhong Zheng², Li Fang¹, 3, Jicheng Liu¹, 3, Chris Hain¹, 3, Jifu Yin¹, 3, Michael Ek²
7. F. Chen, T. Warner, and K. Manning, 2001: *Sensitivity of Orographic Moist Convection to Landscape Variability: A Study of the Buffalo Creek, Colorado, Flash Flood Case of 1996. J. Atmos. Sci., 58, 3204–3223.*
8. Hasan, M., Tsegaye,T., Shi, X., Schaefer, G. and Taylor, G., *Model for predicting rainfall by fuzzy set theory using USDA scan data, 2008*
9. Jim, M., *Application of fuzzy logic in operational meteorology, Carlifornia: Addison Wesley, Longman Inc., 2005*
10. Cirstea, M. N., Dinu, A., Khor, J. G. and Mc Cormink, M., *Neural and Fuzzy Logic Control of Daves and Power.*